

Powerful. Beautiful.

Excellence · Innovation

HPS Series



Shanghai Panelmate Electronics Co., Ltd.

HPS Manual Pulse Generator

HPS Manual Pulse Generator



Features

- Ergonomic design for a more comfortable grip and aesthetically pleasing appearance. A high-performance core encoder and a rotary switch featuring Taiwan-imported components. The built-in strong magnet allows for a base-style hanging box, enabling easier and more secure placement.
- Compatible with various CNC systems, PLCs, and controller systems. Customizable functions can be added, such as rapid traverse, jog, incremental feed, and forward/reverse rotation.
- Multiple encoding modes are available for selection

Namely Rule

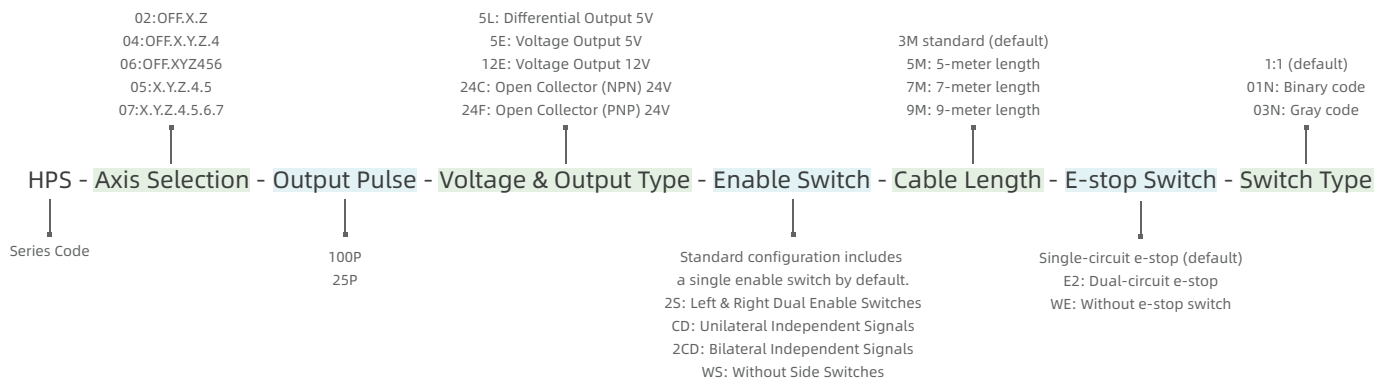





















Specifications

Model	HPS Manual Pulse Generator	
Mechanical	Material	Engineering plastics
	Color	Black
	IP Rating (in accordance with the EU EN60529 standard)	IP54
	Weight	≤0.3kg (No cables included)
	Magnification Selection	Select through the band switch
	Axis Selection	Select through the band switch
	Emergency Stop Button	With (1NC)
	Connection Method	Cable with locking joint (length can be specified), standard 3M
	Mounting	Pendant / Magnetic Mounting
Environment	Operating Temperature	-20~60°C
	Storage Temperature	-40~75°C
Electrical Characteristics	Power Supply	Dc 24V rechargeable lithium battery
	Communication Protocol	Direct Interface
	Pulse Output Type	5L: 5V Differential Output (other options available)
	Output Type	Direct Interface
	Pulses per Revolution	100P

HPS Manual Pulse Generator

Wiring Diagram

* Unused wires must be cut short and properly insulated to prevent exposed copper, Wrap each individual wire tip separately to prevent contact and short circuits.

Comprehensive Handwheel Wiring Diagram			
No.	Color	Signal	Function
Pulse Generator	Red Wire 	VCC	Pulse+ Voltage
	Black Wire 	OV	Pulse- Voltage
	Green Wire 	A	Phase A
	White Wire 	B	Phase B
	Purple Wire 	A-	A-Phase Reversal
	Purple-Black Wire 	B-	B-Phase Reversal
Axis Selection Switch	Yellow Wire 	X	Axis Select X
	Yellow-Black Wire 	Y	Axis Select Y
	Brown Wire 	Z	Axis Select Z
	Brown-Black Wire 	4	Axis Select 4
	Pink Wire 	5	Axis Select 5
	Pink-Black Wire 	6	Axis Select 6
Multiplier Switch	Grey Wire 	X1	Multiplier X1
	Grey-Black Wire 	X10	Multiplier X10
	Orange Wire 	X100	Multiplier X100
E-STOP Switch	Blue Wire 	C	E-Stop Common (C)
	Blue-Black Wire 	NC	E-Stop Normally Closed (NC)
Operation Indicator Light	Green-Black Wire 	LED+	Indicator Cathode (+)
	White-Black Wire 	LED-	Indicator Cathode (-)
Working Terminal	Orange-Black Wire 	COM	Switch Input Common







Warning: Unused wires must be cut short, stripped of excess copper, and individually insulated. Ensure they do not contact other circuits, components, or the casing to prevent short circuits.



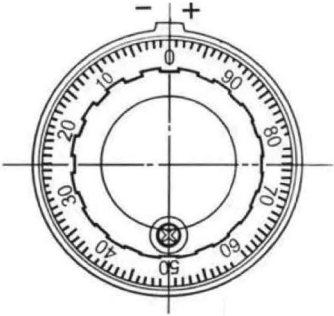

- Please read this specification carefully before wiring to avoid affecting handwheel operation.
- The positive and negative wires of the encoder must not be reversed. Excessive voltage will burn out the device. The standard voltage is 5V. For specific systems (e.g., Mitsubishi uses 12V, PLC uses 24V), connect the voltage confirmed at the time of purchase.
- The COM terminal is the common point for the handwheel switches and must be connected, otherwise the switches will not function.
- Handle the handwheel with care. Impacts can cause damage. Do not apply excessive force when rotating the encoder disk or switches to avoid reducing service life.
- If A-, B- signals are not required, leave them unconnected. The handwheel indicator light operates at DC 5-24V.
- For Mitsubishi systems and PLCs that do not require A-, B- signals, leave these terminals unconnected.



HPS Manual Pulse Generator

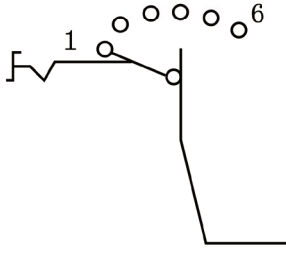

Encoding Table



Encoding Mode Comprehensive Diagram

 <p>Pulse Generator</p>	Wire Color		Signal	Function
		Red	VCC	Connect according to system requirements, e.g., Mitsubishi systems require 12V.
		Black	OV	
		Green	A	
		White	B	
		Purple	A-	This wire/connection is optional if the function is not required. Leave it unconnected if the wire is not provided.
		Purple-Black	B-	



Axis Selection	Wire Color		Signal	Gray Code Diagram Set				Binary Code Diagram Set						
	Function	L4	L2	L1	Axis Code	L4	L2	L1	Axis Code	Wiring				
	L1		Yellow	L1	OFF	0	0	0	000	0	0	0	000	
	L2		Yellow-Black	L2	X Axis	○	○	●	001	○	○	●	001	To L1
	L4		Brown	L4	Y Axis	○	●	●	011	○	●	○	010	To L2
	L8		Brown-Black	L8	Z Axis	○	●	○	010	○	●	●	011	To L3
					4 Axis	●	●	○	110	●	○	○	100	
					5 Axis	●	●	●	111	●	○	●	101	
					6 Axis	●	○	●	101	●	●	○	110	
				7 Axis	●	○	○	100	●	●	●	111		

Feedrate Override	Wire Color		Signal	Function			Axis Code			Function		
	R1	R2	R3	R2	R1	Axis Code	R1	R2	Axis Code	Function		
	R1		Grey	R1	X1	○	●	000	○	●	01	To R1
	R2		Grey-Black	R2	X10	●	●	001	●	○	10	To R2
R3		Orange	R4	X100	●	○	011	●	●	11		
				COM	Common Point		Common Point					

Enable Button	Wire Color	Signal	Function
		Orange-Black	COM Common Point

Custom Button	Wire Color	Signal	Function
		Green-Black	+
		White-Black	-
		Red-Black	Unused function: leave unconnected

E-STOP Switch (STOP)

	Blue	C	Gray Code Diagram Set				Gray Code Diagram Set			
	Blue-Black	NC	L4	L2	L1	Function	R4	R2	R1	Function
			0	0	0	X Axis	0	0	0	0
			0	0	1	Y Axis	0	0	1	1
			0	1	1	Z Axis	0	1	1	10
			0	1	0	4 Axis	0	1	0	100
			1	1	0	5 Axis	1	1	0	1000
			1	1	1	6 Axis				
			1	0	0	7 Axis				

Note: Pulse Generator The red wire must be connected according to system voltage requirements.

Examples: [Mitsubishi systems: 12V](#) [PLC systems: 24V](#)

- If A-, B- signals are not supported, leave them unconnected.
- Handle the handwheel with care. Avoid impacts or excessive force when rotating the encoder disk or switches, as rough operation may shorten the product's service life.
- For Mitsubishi and PLC systems without A-, B- signals, do not connect these terminals.

Technical Drawings unit: mm

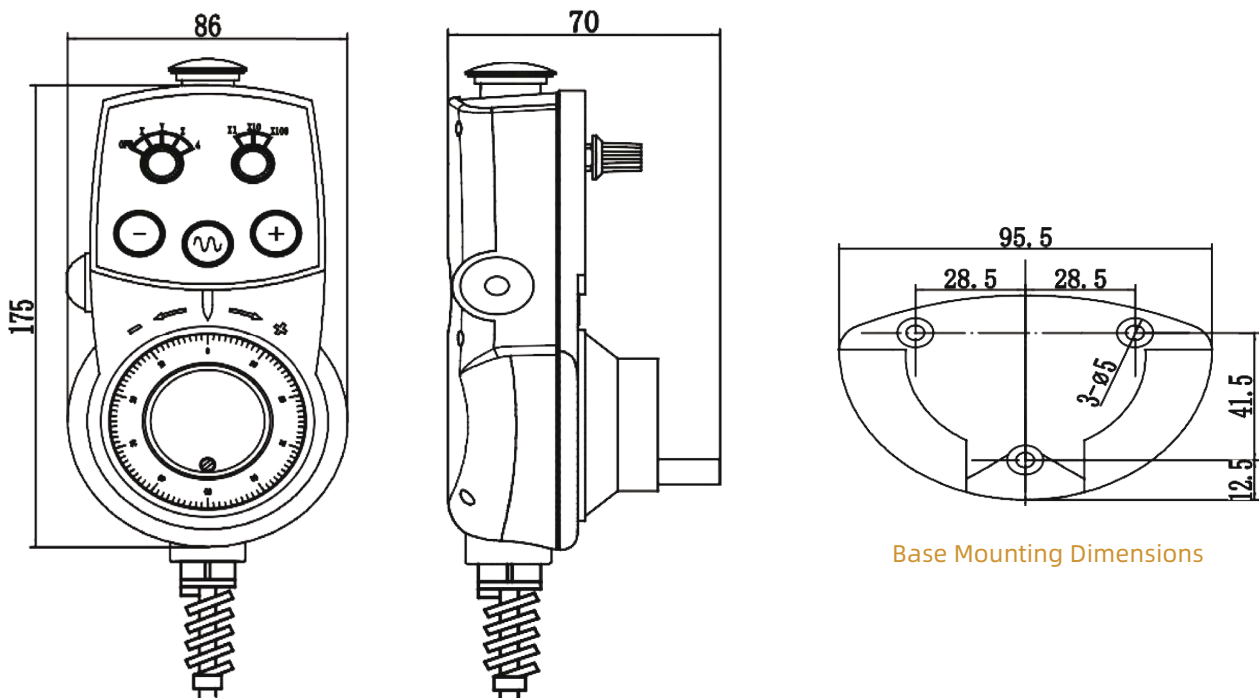

Base Mounting Dimensions